



ROLLER-868

User Manual

Table of contents

Important safety instructions	3
Important safety instructions for installation	3
Important safety instructions for use	3
Use of the system	3
General description	4
Technical data	4
Technical data: Receiver	4
Technical data: Panel	4
Installation	5
Operating	5
Control panel operations	5
<i>Options selector</i>	5
<i>Pushbuttons</i>	5
A) Semi-automatic / automatic operating	6
<i>Possible connections:</i>	6
B) Dead man operating	7
<i>Possible connections:</i>	7
Time programming	9
Receiver operations	9
Manual programming	9
1) <i>Normal programming</i>	9
2) <i>Open/close programming</i>	9
Programming by radio	9
Code cancellation (total reset)	9
Notes	10
Regulatory Data	12
EU Declaration of conformity	12

Important safety instructions

Important safety instructions for installation



Disconnect the power supply whenever you proceed to the installation, maintenance or repair of the equipment.

- Before installing the panel, remove all unnecessary ropes or chains and disable any equipment such as locks that is not necessary for the automatic operation.
- Before installing the panel, check that the door is in good mechanical condition, correctly balanced and that it opens and closes correctly.
- Install the manual unlocking device at a height lower than 1.8m.
- Install any permanent control next to the door away from any moving part and at a minimum height of 1.5m.
- For permanently connected equipment, an easily accessible power disconnection device must be incorporated into the wiring. It is recommended that this be of the emergency switch type.
- If the control panel is supplied without emergency stop button, this will be incorporated in the installation, connecting it to the STOP terminal.
- For correct use of the security edge, this must never be activated when the door is fully closed. It is wise to install the ends of run before activating the edge.
- This equipment can only be handled by a specialist fitter, by maintenance staff or by a suitably trained operator.
- To connect the power supply and motor wiring, 2.5 mm² section terminals must be used.
- Use protective goggles when handling the equipment.
- Fuses must only be handled when the appliance is disconnected from the mains.
- The instructions for using this equipment must remain in the possession of the user.
- European door normative EN 12453 and EN 12445 specify the following minimum protection and door safety levels:
 - for single-family dwellings, prevent the door from making contact with any object or limit the force of contact (e.g. safety band), and in the case of automatic closing, it is necessary to complement this with a presence detector (e.g. photocell).
 - for communal and public installations, prevent the door from making contact with any object or limit the force of contact (e.g. safety band), and complement this with a presence detector (e.g. Photocell).

Important safety instructions for use

- Do not allow children to play with the door controls.
- Keep the remote controls out of the reach of children.
- Watch the door movement and keep people away until the door is fully open or closed.
- Precaution when operating the manual unlocking device, as the door may suddenly fall due to the bad condition of the springs or door unbalance. Details on how to use the manual unlocking device must be provided by the manufacturer or the device installer.
- Examine the installation frequently, especially the cables, springs and supports, to detect signs of wear, damage or unbalance. Do not use the door if repair work or adjustments are required, as this may cause damage.

Use of the system

Designed for automation of garage doors, in accordance with the general description. Not guaranteed for other uses. The manufacturer reserves the right to alter equipment specifications without prior notification.

General description

Control panel with built-in receiver for axis centre motors and operators for roller doors and shutters. It enables the memorising of 15 radio transmitters using the programming button.

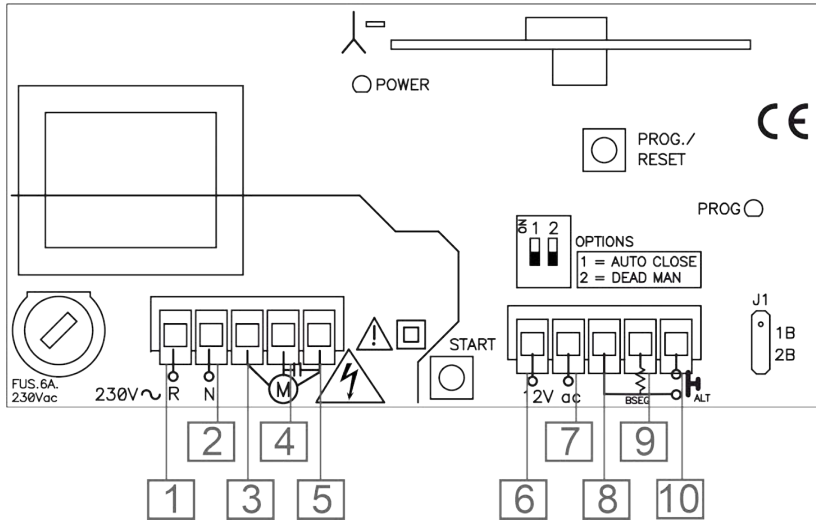

- 1- Power supply 230V ac
- 2- Power supply 230V ac
- 3- Common motor
- 4- Motor (CLOSE)
- 5- Motor (OPEN))
- 6- Photocell power supply output 12Vac
- 7- Photocell power supply output 12Vac
- 8- Common buttons
- 9- Safety edge resistive contact 8k2 (until 2 in parallel)
- 10- Start button (NA)

Technical data

Technical data: Receiver

Frequency	868,35MHz
Coding	High safety changing code
Memory	15 codes

Technical data: Panel

Supply	230V AC \pm 10% / 115Vac \pm 10%
Maximum motor power	0,75CV / 0,50CV
Standby/Op. consumption	23mA / 42mA (without photocells)
Motor fuse	6A
Inputs	Start and safety edges
Photocell power supply output	12Vac (max 130mA)
Handling time	1 second - 2 minutes (45 seconds by default)
Op. temperature	-20°C to +85°C
Watertightness	IP54 (with IP65 packing seal)
Box dimensions	140x220x55mm

Installation

Fit the rear of the box to the wall using the raw plugs and screws supplied. Pass the cables through the bottom of the equipment. Connect the power supply cables to the terminals on the printed circuit, following the indications engraved on the board. Fit the front of the equipment to the rear using the screws supplied.

Operating

Control panel operations

Power supply: The green pilot light indicates the correct power supply to the equipment.

Options selector

Function	OFF position (default option)	ON position
1 = AUTO CLOSE	Semi-automatic operating = it does not closes automatically	Automatic operating = it closes automatically
2 = DEAD MAN	Semi-automatic operating or automatic depending on 1 selector	Dead man operating

Pushbuttons

START	Black	It carries out the same function as a NC button in ALT terminals
PROG./RESET	Red	It carries out two functions: time programming and transmitter programming

A) Semi-automatic / automatic operating

The Start button carries out the following function. When the button is pressed for the first time, the motor starts, when pressed for the second time (if it has not reached the limit switch) it stops, and it closes automatically or it waits for the third time to close. Automatic closure will only be carried out if the entire opening movement has been completed and option switch 1 is turned to ON.

Possible connections:

- A1) Connection of two safety edge in parallel (open and close):** This acts on opening and closing, causing stoppage and 1 second inversion. The connection of a start button is optional. J1 in OFF. A security device (photocells, normally closed contact) can be connected in series with the safety edge. The activation of this security device causes a stoppage and a total reversion of the door.

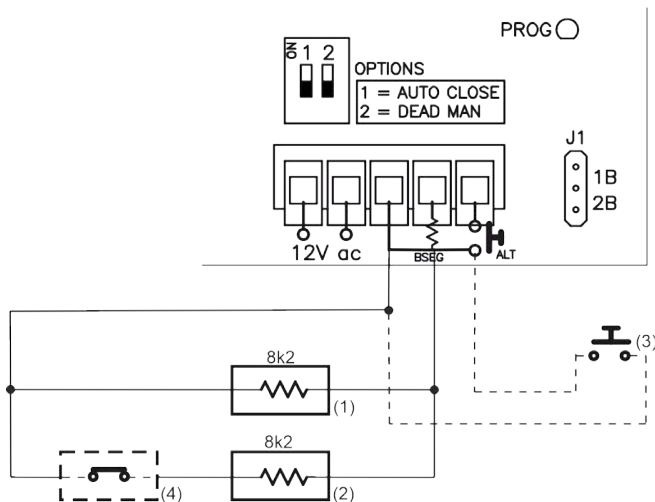

- A2) Connection of a safety edge (open or close):** This acts on opening and closing, causing stoppage and 1 second inversion. The connection of a start button is optional. Situate the jumper J1 on 1B position. A security device (photocells, normally closed contact) can be connected in series with the safety edge. The activation of this security device causes a stoppage and a total reversion of the door.

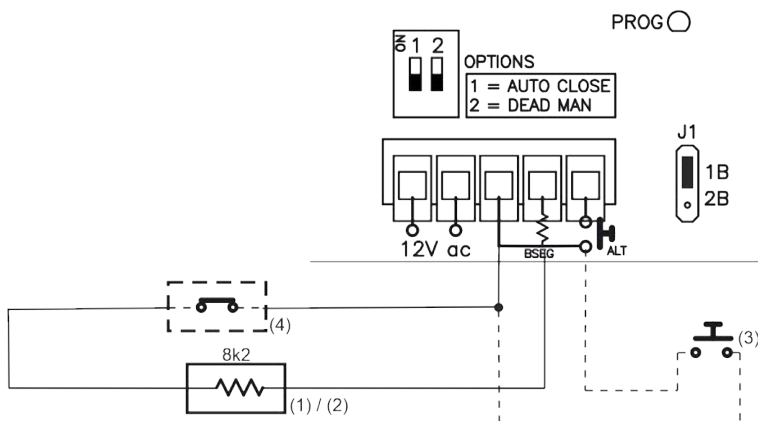

- **A3) Connection without safety edges:** The connection of a start button is optional. Situate the jumper J1 on 2B position.

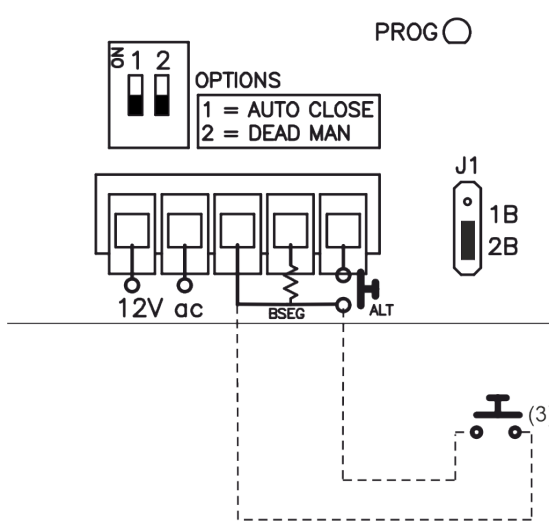

B) Dead man operating

Possible connections:

- **B1) Open/close dead man operating:** Optionally two pushbuttons could be connected. One on the ALT terminal that will operate as a dead man button in opening, and the other on the BSEG terminal that will operate as a dead man button in closing. The J1 jumper must be situated on 2B (operating without safety edges).

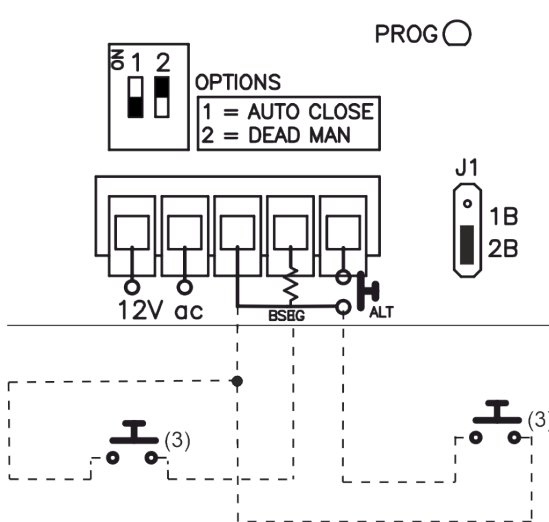

• **B2) Semi-automatic operating in opening and dead man operating in closing:** Optionally two pushbuttons could be connected. One on the ALT terminal that will operate as an opening/stop button in opening, and the other on the BSEG terminal that will operate as a dead man button in closing. In case of using a safety edge in opening, it is necessary to remove the J1 jumper. If safety edges are not used, situate the J1 jumper on 1B.

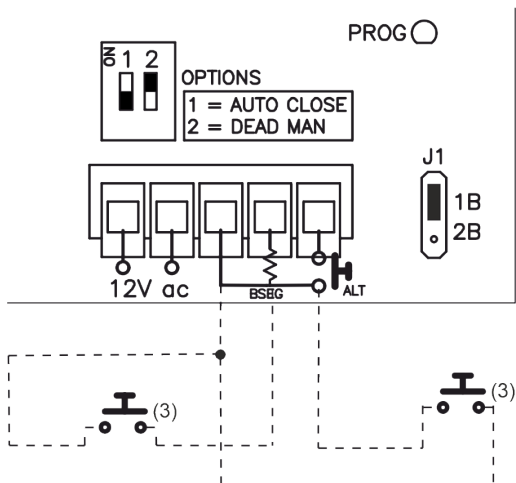
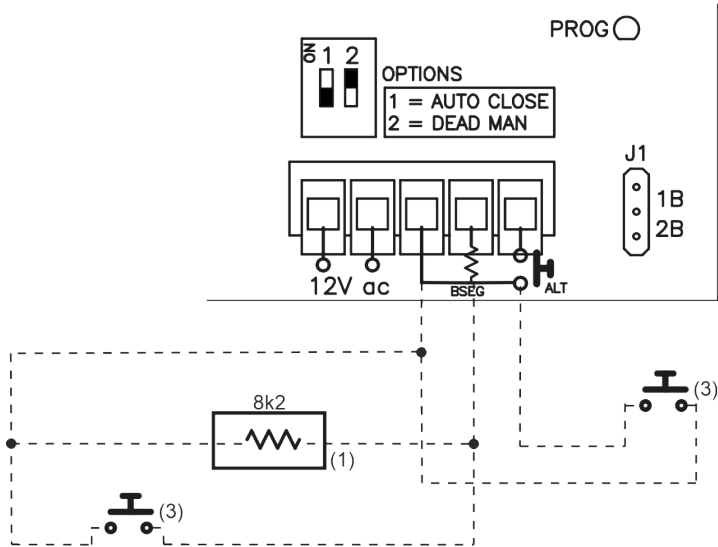

To operate in dead man by radio is possible with the wireless devices for dead man operation.

- (1) - Safety edge in opening
- (2) - Safety edge in closing
- (3) - NO pushbutton
- (4) - NC security contact
- (Optional)

Time programming

The door must be completely closed before starting time programming.

Press the PROG/RESET button for 1 second to enter programming. The red PROG pilot light will come on and the equipment will emit an acoustic signal. Use the ALT / START button to programme the run.

The first time ALT / START is pressed, the door opens and begins to memorise the handling time. The second time it is pressed, it stops, ends to memorise the handling time and begins to temporise the waiting time for autoclosing.

The third time it is pressed, ends to temporise waiting time for autoclosing, closes and programming is exited (the red pilot light goes out).

Receiver operations

Upon receiving a code, the equipment checks whether it is in its memory, activating the corresponding relay.

Manual programming

1) Normal programming

1) Normal programming Press the programming button for 1 sec. The programming pilot light will come on and the equipment will emit an acoustic signal. The equipment will enter normal programming. Send the code and the channel to be programmed by pressing the transmitter.

By pressing the transmitter channel, opening and closure is activated in step-by-step operating mode.

2) Open/close programming

Press the programming button until the red pilot light flashes and the equipment emits a short acoustic signal. The equipment will now have entered open/close programming. Press the required channel of the transmitter to be programmed. The first channel opens and the second closes (3rd channel opens and 4th channel closes).

 Each transmitter channel can be configured independently on the equipment, occupying only one memory position.

Every time a transmitter is programmed, the equipment will issue an acoustic signal for 0.5 sec. After 10 seconds without programming or by pressing the programming button, or by pressing the first two buttons of a transmitter (depending on the programming mode), the equipment will exit programming mode, issuing two 1 sec. acoustic signals. If, on programming a transmitter, the equipment memory is full, it will issue seven 0.5 sec. acoustic signals and exit programming.

Programming by radio

To enter programming, press the first two buttons on a transmitter that has already been registered on the equipment. The equipment will issue a 1 sec. acoustic signal. On pressing any button on the new transmitter, the equipment will issue another 1 sec. acoustic signal to indicate that it has been memorised. The new transmitter will maintain the same channel configuration as the transmitter registered.

After 10 seconds without programming or by quickly pressing the programming button or pressing the first two transmitter buttons, the equipment will exit programming mode, issuing two 1 sec. acoustic signals.

Code cancellation (total reset)

In programming mode, the programming button is held down for over 10 sec. The equipment will issue 10 short acoustic warning signals followed by others at a faster pace to indicate that the operation has been successful. The equipment is now in programming mode. The pilot programming light will also follow the acoustic indications by flashing.

After 10 seconds without programming or quickly pressing the programming button, the equipment will exit programming mode, issuing two 1 sec. acoustic signals.

Regulatory Data

EU Declaration of conformity

JCM TECHNOLOGIES, S.A. hereby declares that the product **Roller868** complies with the relevant fundamental requirements of the RED Directive 2014/53/EU, as well as with the Machine Directive 2006/42/EC whenever its usage is foreseen; and with the 2011/65/EU RoHS Directive.

See website www.jcm-tech.com/declarations/

JCM TECHNOLOGIES, SA
C/COSTA D'EN PARATGE, 6B
08500 VIC (BARCELONA)
SPAIN

