



jcmtechnologies



user manual

F30 1.5KW

EN

Safety instructions – Important annex.....	3
Important safety instructions for installation.....	3
Important safety instructions for use.....	4
Introduction.....	5
General description.....	5
Detailed description.....	6
Installation.....	9
Fixations of the control panel.....	9
Connections.....	10
Configuration/start-up.....	14
Option selector.....	14
Connect the power supply.....	14
Initialization of inverter parameters.....	15
Speed ramps adjustment.....	16
Checking motor direction.....	18
Programming.....	18
Manoeuvre programming with digital end limit switch (ENCODER).....	18
.....	19
Fine adjustment (for programming with encoder).....	19
Manoeuvre programming with limit switches.....	20
Partial manoeuvre programming.....	21
Verification.....	21
Maintenance.....	23
Fuse replacement.....	23
Set parameters to default values.....	23
Warning of maintenance.....	23
Use of the system.....	23
Troubleshooting.....	24
Troubleshooting.....	24
Indicator light for possible faults, LED ERROR.....	24
Technical data.....	25
Electrical parameters.....	25
Regulatory data.....	26
EU Declaration of conformity.....	26
EKCA Declaration of conformity.....	26

Important safety instructions for installation

- Disconnect the power supply before manipulating the equipment in any way.
- Before installing the panel, remove all unnecessary ropes or chains and disable any equipment such as locks that is not necessary for the automatic operation.
- Before installing the panel, check that the door is in good mechanical condition, correctly balanced and that it opens and closes correctly.
- Install the manual unlocking device at a height lower than 1.8m.
- Install any permanent control next to the door away from any moving part and at a minimum height of 1.5m.
- An easily accessible power supply disconnection device must be fitted to the wiring for permanently connected equipment. This device must ensure multi-pole cut-off of the power supply. It is advisable for this to be an emergency breaker/isolator type switch.
- If the panel is supplied without an emergency stop button, this must be incorporated into the installation, connecting it to the STOP terminal.
- For correct use of the security band, this must never be activated when the door is fully closed. It is recommended to install the limit switches before activating the band.
- This equipment can only be manipulated by a specialist fitter, by maintenance staff or by a suitably trained operator.
- To connect the power supply and motor wiring, terminals with a cross-section of 2.5 mm² must be used.
- Use protective eyewear for handling the equipment.
- Fuses must only be handled when the appliance is disconnected from the power supply.
- The instructions for using this equipment must remain in the possession of the user at all times.
- European door standard EN 12453 and EN 12445 specify the following minimum protection and safety levels in doors:
 - for single-family homes, prevent the door being able to come into contact with any object or limit the contact force (e.g. safety edge), and, in the event of automatic closure, a presence detector (e.g. photocell) must be added.
 - for communal and public installations, prevent the door being able to come into contact with any object or limit the contact force (e.g. safety edge) and detect presence (e.g. photocell).



F30 1.5KW control panel switches automatically to dead man mode when safety devices are active or defective. Therefore, all controls work as “hold-to-run” controls.



WARNING: IN ACCORDANCE WITH THE EN 13241-1 AND EN 12453-1 STANDARD CONCERNING PRESSURE MAINTAINED CONTROL DEVICES:

- “The person operating the door must have a direct view of the doorway, must be near the door (5 meters maximum) during movement of the door and should not find itself in a dangerous position”. **Any adjustment of the radio range out of these recommendations, undertakes the installer in terms of responsibility for injury or damage.**
- “Releasing of the pressure maintained control device should stop the door movement before it scrolls 5cm”.

Important safety instructions for use

Do not allow children to play with the door controls.

Keep the remote controls out of the reach of children.

Watch the door movement and keep people away until the door is fully open or closed.

Take care when operating the manual unlocking device, as the door may suddenly fall due to the bad condition of the springs or a poorly balanced door. Details on how to use the manual unlocking device must be provided by the manufacturer or the device installer.

Examine the installation frequently, especially the cables, springs and supports, to detect signs of wear, damage or imbalance. Do not use the door if it needs to be repaired or adjusted, as doing so may cause injury.



IMPORTANT
NOTE



SAFETY
WARNING



Installation



Maintenance



Connections



Programmation

Introduction

General description

Control panel with frequency inverter 1.5KW with position control using JCM, Elektromaten or Kostal digital end limit switches or mechanical limit switches, designed for high speed doors.

Is composed by:

- Motor brake outputs and flashes at 230Vac, and voltage-free contact outputs to indicate the status of door open and door closed.
- One 24Vac output and two 24Vdc outputs for the connection of photocells with self-test or other accessories such as radars. These outputs provide a maximum of 700mA shared between the three.
- Inputs for opening and closing buttons, as well as for selecting total or partial opening.
- Inputs for safety contacts, a safety edge and a stop.
- External card connectors: Motion STICK receiver, RSEC3 RadioBand receiver, TL-CARD-V traffic light card and MTC1 magnetic detector card.

In case of activation of a safety input, if any control input is kept active, the movement of the door becomes by maintained pressure (Dead man), and the safety input LED on the cover flashes, indicating the dead man mode.

This control panel complies with the current electrical safety regulations EN 60335-1: 2012.

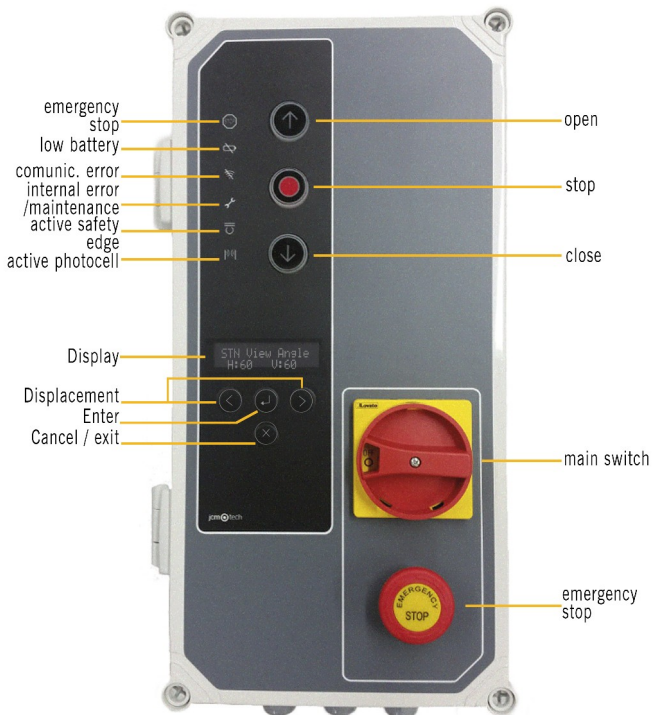

Detailed description

1- FUSE

1A/250V

2- AUTOCLOSE TIME

Min=3s - Max=180s

3- RECEIVER

Motion STICK / DCS RACK receiver connector

4- MTC

Connector for magnetic detector card MTC

5- REMOTE CONNECTOR

Connection for VERSUS-PROG programmer

6- EXPANSION CARDS

RSEC3 RadioBand receiver connector

TL-CARD-V Connector

7- PROGRAMMING PUSHBUTTONS

Open and close manoeuvre programming

8- OPTION SELECTORS

9- 24VDC OUTPUT

Fixed output 700mA, shared with all 24v outputs

10- 24VDC / TEST OUTPUT

Output for photocell tests, 700mA shared with all 24v outputs

11- PROTECTION EARTH (MANDATORY)

Connection for earth

12- SAFETY CONTACT INPUTS

Connection for photocells 1 (Open) and photocells 2 (Close)

13- 24VDC / TEST OUTPUT

Output for photocell tests, 700mA shared with all 24v outputs

14- MOTOR

Connection for motor U (Open) V (Close) W (Common)

15- POWER SUPPLY

Power supply input connection

16- PROTECTION EARTH (MANDATORY)

Connection for earth

17- ENTRADAS BANDA DE SEGURIDAD / STOP

Connection for 8k2 band / optical band / Stop pushbutton

18- PUSHBUTTONS INPUTS

Connection for external buttons (Partial opening, Opening and Closing)

19- END LIMIT SWITCHES

Open and close end limit switches

20- OPENED - Door status output

Voltage-free contact (indicates door opened)

21- CLOSED - Door status output

Voltage-free contact (indicates door closed)

22- FLASH LAMP

Connection for 230Vac flash lamp

23- MOTOR BRAKE

Connection for 230Vac motor brake

24- ENCODER CONNECTOR

Remove the jumper for connecting the encoder



Fixations of the control panel

Install the control panel vertically on the wall at a height of 1.5m and following the assembly instructions.

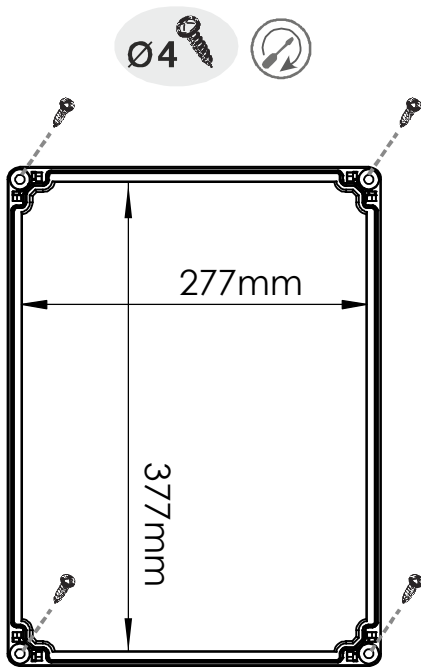

Do not pierce the box for cable entry. Use the cable glands enabled for it.

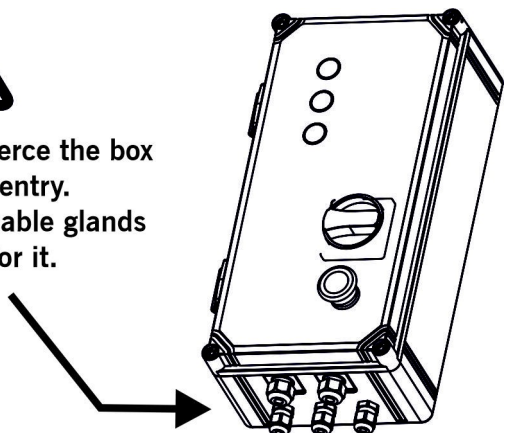

F30 1.5KW

OUTPUTS

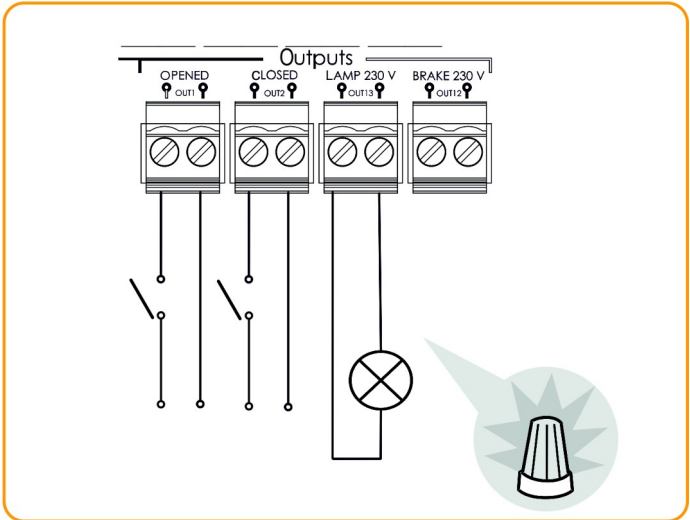
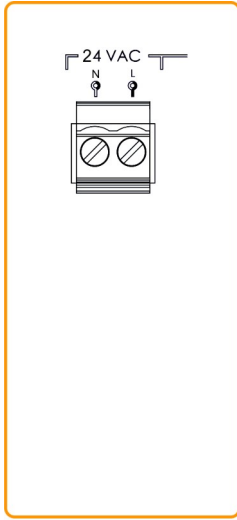

PUSHBUTTONS

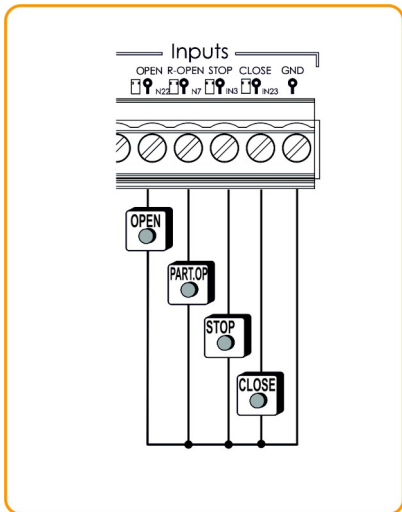

LIMIT SWITCHES

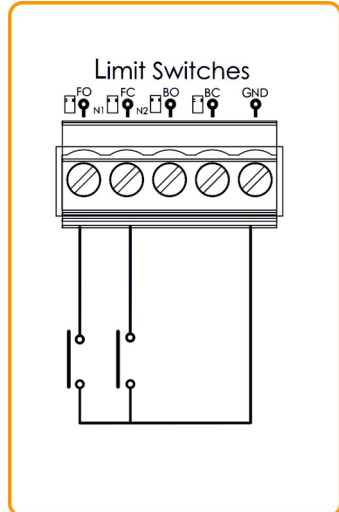

OPTO SAFETY EDGE INPUT / 8K2 SAFETY EDGE INPUT (AUTOEDGE)

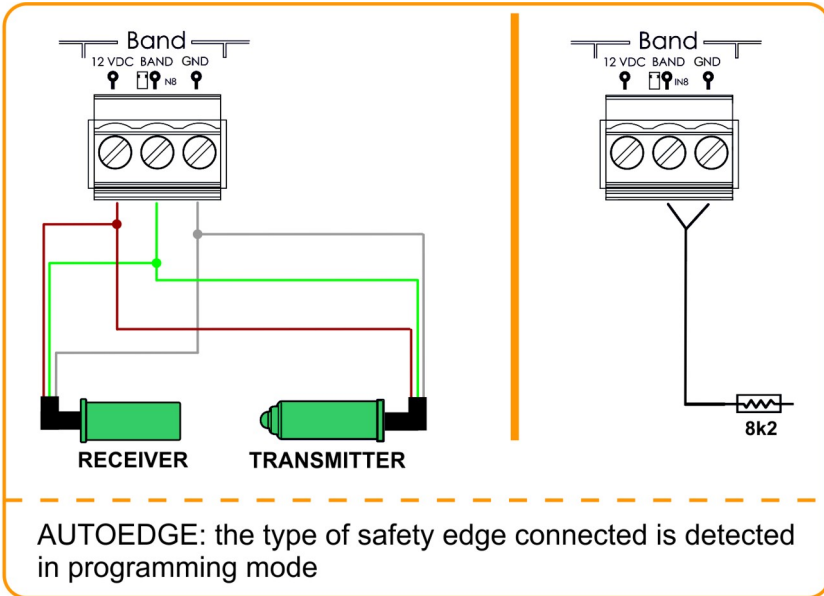

PHOTOCELLS INPUTS

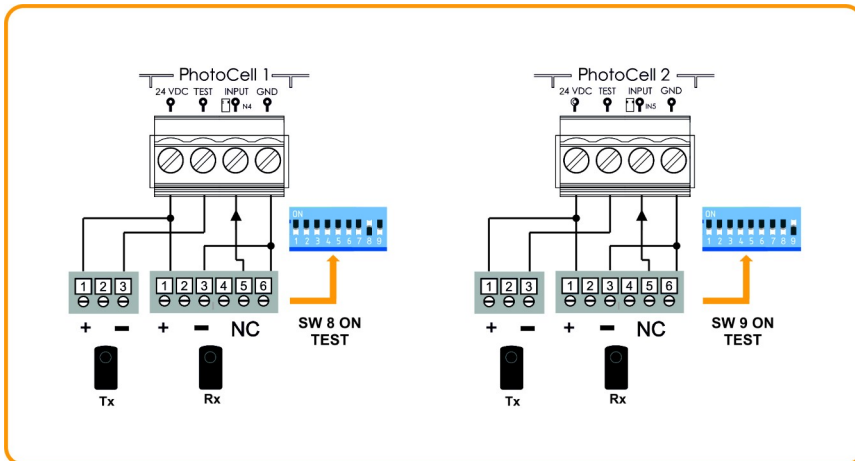

Normally, by default, PhotoCell1 is configured for opening safety and PhotoCell 2 for closing safety.

Check the configuration of the control panel parameters to be sure.

NPN PHOTOCELLS INPUTS

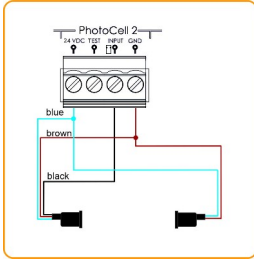

NPN PHOTOCELL BARRIERS INPUTS

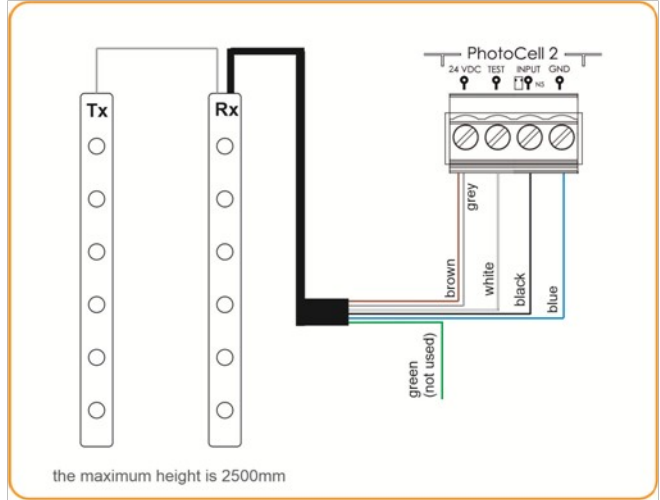

FSS PHOTOCELL BARRIERS INPUTS

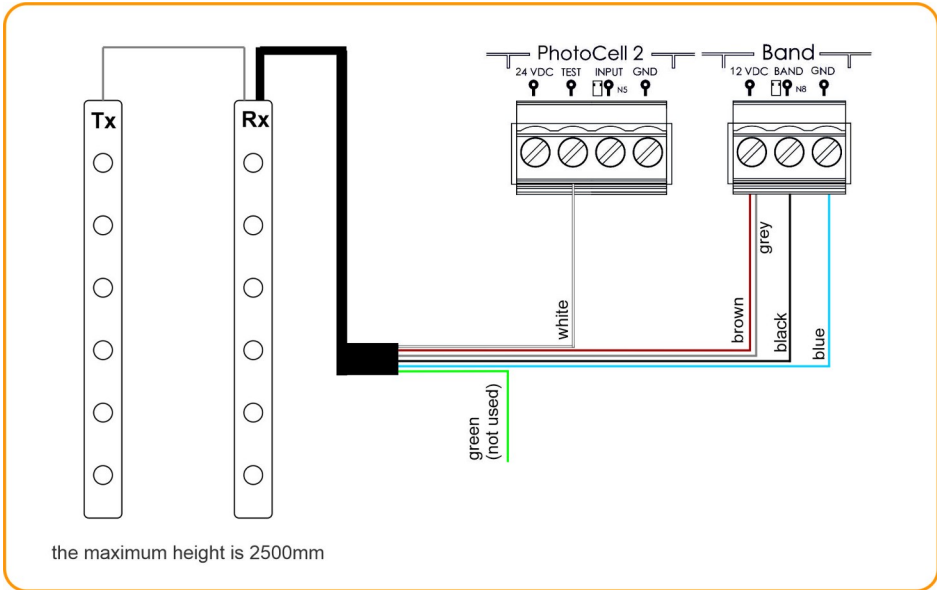



Configuration/start-up

Option selector

By default all selectors leave the factory set to OFF.

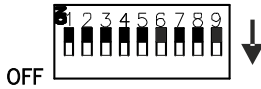

Do not closes automatically	1- AUTOCLOSE	Closes automatically
Functioning without dead man on opening	2- DM OPEN	Activates the dead man on opening manoeuvre
Functioning without dead man on closing	3- DM CLOSE	Activates the dead man on closing manoeuvre
Without pre-flash	4- NO PREFLASH / PREFLASH	Activates the pre-flash function
Activates motor brake function	5- BREAK / NO BREAK	Deactivates motor brake function
Start button performs an stop at opening	6- NO STOP ON OPENING	Start button opens until total opening
Deactivates closing by security contact	7- CLOSE BY SEC.CL.	Activates closing by security contact
Does not perform auto-test of the opening security contact	8- TEST OP	Activates the opening security contact auto-test.
Does not perform auto-test of the closing security contact	9- TEST CL	Activates the closing security contact auto-test.

SELECTOR OPTIONS

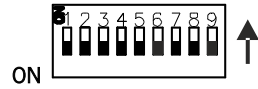

Do not closes automatically	1- AUTOCLOSE	Closes automatically
Functioning without dead man on opening	2- DM OPEN	Activates the dead man on opening manoeuvre
Functioning without dead man on closing	3- DM CLOSE	Activates the dead man on closing manoeuvre
Without pre-flash	4- NO PREFLASH / PREFLASH	Activates the pre-flash function
Activates motor brake function	5- BREAK / NO BREAK	Deactivates motor brake function
Start button performs an stop at opening	6- NO STOP ON OPENING	Start button opens until total opening
Deactivates closing by security contact	7- CLOSE BY SEC.CL.	Activates closing by security contact
Does not perform auto-test of the opening security contact	8- TEST OP	Activates the opening security contact auto-test.
Does not perform auto-test of the closing security contact	9- TEST CL	Activates the closing security contact auto-test.

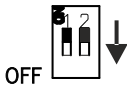

Deactivates the fine adjustment function	1- FINE ADJ	Activates the fine adjustment function (only functioning with digital end limit switches)
Activates functioning by digital end limit switches connector (ENCODER connector)	2- ENCODER ABS/ LIMIT SWITCH	Activates functioning by mechanical limit switches input

SELECTOR OPCIONES



Deactivates the fine adjustment function	1- FINE ADJ	Activates the fine adjustment function (only functioning with digital end limit switches)
Activates functioning by digital end limit switches connector (ENCODER connector)	2- ENCODER ABS/ LIMIT SWITCH	Activates functioning by mechanical limit switches input

Connect the power supply

Before powering up the panel, leave the door in half way.

Power up the control panel and first of all initialize the inverter parameters and adjust the speed ramps.

Initialization of inverter parameters

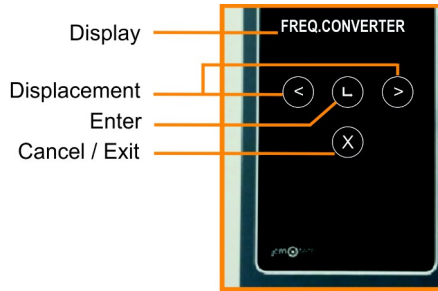

To initialize the inverter parameters, press the ◀ or ▶ key for 2s to enter PROGRAMMING, select the PARAM CONFIG menu with the ◀ or ▶ key and validate with the Ⓛ Enter key.

Once inside, select the FREQ.CONVERTER n with the ◀ or ▶ key and validate with the Ⓛ key. The message PLEASE WAIT DATA LOAD will appear on the display.

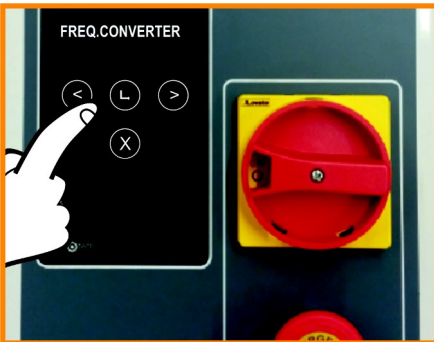

Select the desired parameter to modify with the ◀ or ▶ key and validate with the Ⓛ Enter key. The message PLEASE WAIT DATA LOADING will appear on the display. Press the ▶ key to move the pointer and press the Ⓜ to increase the number. Press the Ⓛ Enter key to validate.

The parameters that must be entered and found in the motor plate are the following:

FC Motor Freq: motor frequency

FC Motor Power: engine power

FC MotorCurrent: motor current

FC Motor RPM: motor revolutions per minute

Speed ramps adjustment

Once the "open door" and "closed door" points have been programmed, the programming of the door will be calculated automatically from the VERSUS parameters indicated below.

Follow the initialization sequence of the drive parameters on page above to access them.

The door speed profiles will be calculated according to the following pattern:



*Once the sequence has been programmed, the mentioned parameters can be changed with the appropriate display or programmer and the speed profiles will be recalculated.

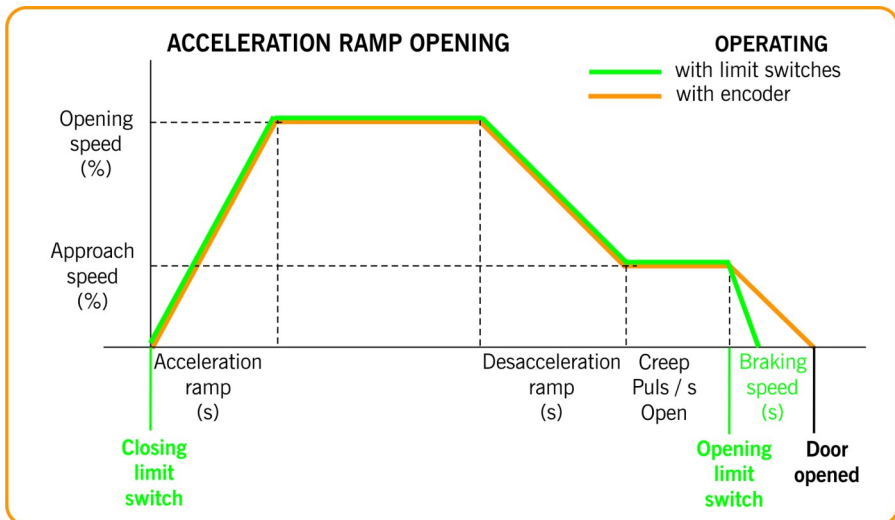

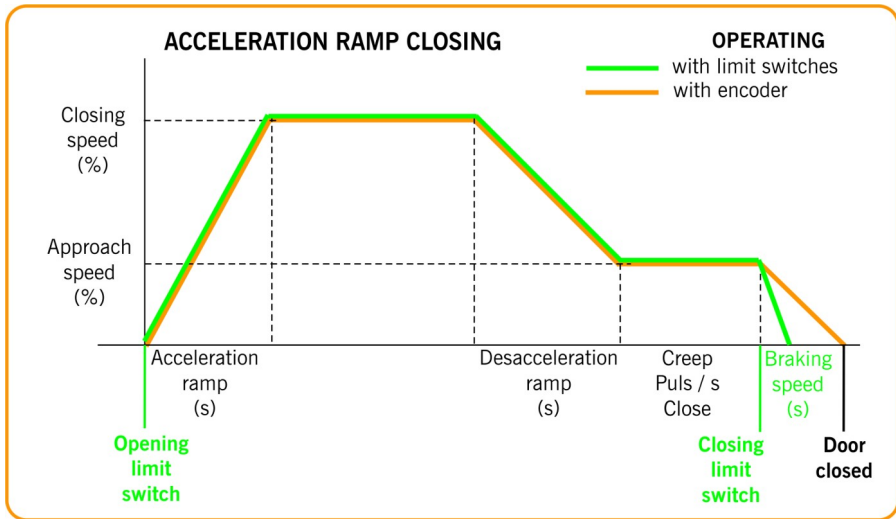

- **FC PosRamp Time:** acceleration ramp (seconds from 0% to 100% of the speed)
- **FC HighSpeedOpen:** opening speed (%)
- **FC NegRampTime:** deceleration ramp (seconds from 100% to 0% of the speed)
- **FC Creep Speed:** approach speed (%)
- **Creep Puls Open:** approach pulse / time (seconds when operating with limit switches)
- **FC HighSpeedClose:** closing speed (%)
- **Creep Puls Close:** approach pulse / time (seconds when operating with limit switches)
- **FC QuickStopTime:** braking ramp (seconds from 100% to 0% of the speed) when operating with limit switches

Other parameters:

- **FC DCBrake Speed:** indicates the speed from where DC Brake is activated
- **FC Brake Speed:** indicates the speed from where Brake is activated

Checking motor direction

1. Turn the Options 2 selector to the ON position
2. Press the Open button on the cover and check that the door opens.
3. If it fails to open, disconnect the power supply and swap over the wires to the motor. Or change the parameter P38 (Motor Out Invert) to ON, with the VERSUS-PROG programmer.



Programming

Once configured all the parameters and performed the start-up, proceed to program it.

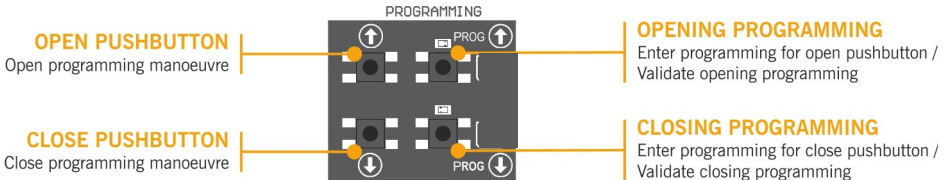

When programming, it is preferable to make medium and/or long runs to short ones (in order to improve hysteresis and inertia).

The manoeuvre programming will be done in creep speed.







Manoeuvre programming with digital end limit switch (ENCODER).





Turn the option 2 of the selector 2 to the OFF position.

Only the buttons   on the board can be used, and these will function in dead man mode.

PROGRAMMING FOR OPENING

1. Press the **PROG**  button for 3 seconds, the indicator light will come on.
2. Position the door in the door open point using the buttons  . It is advisable to make long runs in order to ensure a correct adjustment.
3. Once the door is in the desired “door opened” position, press the **PROG**  button to validate the “door opened” position. The indicator light will flash a number of times and then go out.

PROGRAMMING FOR CLOSING

1. Press the **PROG**  button for 3 seconds, the indicator light will come on.
2. Position the door in the door closed point using the buttons  . It is advisable to make long runs in order to ensure a correct adjustment.
4. Once the door is in the desired “door closed” position, press the **PROG**  button to validate the “door closed” position. The indicator light will flash a number of times and then go out.



The **STOP** button aborts the programming sequence.



If you connect a RSEC3 to use external safety elements, you must reprogram the maneuver.



Fine adjustment (for programming with encoder)





Once the manoeuvre has been programmed, a fine adjustment of the programmed “door open” and “door closed” position can be made.

Situate option 1 of the selector 2 in the ON position. The indicator lights will flash continually.





In this mode, door does not moved.



MODIFYING THE “DOOR OPENED” POSITION

1. Press the **PROG**  button. The indicator light will come on.
2. Press the  or  button to increase or decrease the “door open” position. Each press will be approximately equivalent to 1 cm (this value depends on the absolute encoder resolution).
3. Once the “door opened” position has been adjusted, press the **PROG**  button to validate the “door opened” position”. The indicator light will flash a number of times and then go out.

MODIFYING THE “DOOR CLOSED” POSITION

1. Press the **PROG**  button. The indicator light will come on.
2. Press the  or  button to increase or decrease the “door closed” position. Each press will be approximately equivalent to 1 cm (this value depends on the absolute encoder resolution).
3. Once the “door closed” position has been adjusted, press the **PROG**  button to validate the “door closed” position”. The indicator light will flash a number of times and then go out.

Situate option 1 of the selector 2 in the OFF position. The indicator lights will turn off.



Manoeuvre programming with limit switches

Turn the option 2 of the selector 2 to the ON position.



Jumper on the encoder connector must be plugged.

The limit switches need to be adjusted before programming, and the door positioned in the “door closed” position.

PROGRAMMING FOR OPENING

1. Press the **PROG**  button for 3 seconds. The indicator light will come on.
2. Press the Open button . The door will open automatically until it finds the opening limit switch.

PROGRAMMING FOR CLOSING

3. Press the **PROG**  button for 3 seconds. The indicator light will come on.
4. Press the Open button . The door will close automatically until it finds the closing limit switch
5. End of programming, the indicator light will flash several times and then go out.

Partial manoeuvre programming

Bridge the Partial opening input IN7 and proceeds to programme according to encoder or limit switches, as desired.

In this case, the “door opened” position will be located at the half way point of the run.

Verification





Verify that the control panel works correctly

Once the control panel is properly wired and programmed, check that the entire system (accessories included) is working correctly.

Safety edge Check that the led  is off.

If you activate the safety edge when the door is closing, the led  will light to indicate the activation of the safety edge.

Photocells Check that the led  is off.

If you activate the safety edge when the door is closing, the led  will light to indicate the activation of the photocell.

Quality of communication (in case of RSEC3 connected)

To ensure that the quality of radio communication is good enough, check that the LED  is off. If it is permanently activated, check RadioBand3.



Maintenance

Fuse replacement

When connecting the equipment to the power supply, if the front panel does not light up, open the front cover and replace the fuse with another of the same characteristics.

Set parameters to default values

If you desire to set the parameters to the default values, you must enter into the frequency converter parameters menu as explained below, and select the RESTORE DEFAULT option.



To initialize the inverter parameters, press the **◀** or **▶** key for 2s to enter PROGRAMMING, select the PARAM CONFIG menu with the **◀** or **▶** key and validate with the **L** Enter key.

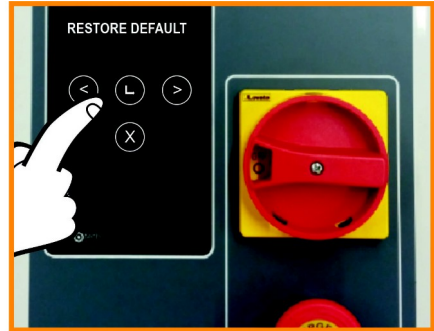

Once inside, select the RESTORE DEFAULT menu with the **◀** or **▶** key and validate with **L** Enter key. Then select RESTORE ALL, and the message CONTINUE? will appear on the display. Press **L** Enter key to validate.

Warning of maintenance

The limit of maneuvers has been overflowed. You must reset the PCO parameter (Maintenance counter) to 0, with the display menu or with the VERSUS-PROG programmer.







Use of the system

Designed for the automation of high speed doors in accordance with the general description. Not guaranteed for other uses.

The manufacturer reserves the right to alter equipment specifications without prior notification.

Troubleshooting



Troubleshooting

INDICATOR	LIGHTING	SOLUTION
	Emergency stop activated	
	Detection of low battery	Check the batteries of the transmitter
	Radio communication error	Check the radio signal. Check the batteries, reprogram or change the position of the equipment.
	Lighting: installer mode Flashing: warning of maintenance	See maintenance section
	Lighting: closing photocell activation Flashing: indicates the reverse movement after a safety detection	
	Lighting: RS3 / safety edge activation Flashing: indicates the reverse movement after a safety detection	

Indicator light for possible faults, LED ERROR

ERROR	LED ERROR	INDICATION	SOLUTION
Er02 INTERNAL ERROR	10 slow flashes 2 quick flashes	Internal error	Consult the technical service
Er09 MAX. PROG. TIME	10 slow flashes 9 quick flashes	The maximum permitted programming time has been exceeded	Program a shorter time manoeuvre than the maximum permitted
Er12 CLOSING BAND ERROR	1 slow flashes 2 quick flashes	Closing safety band error	Check the closing safety band connections
Er13 OPENING BAND ERROR	1 slow flashes 3 quick flashes	Opening safety band error	Check the opening safety band connections
Er19 CLOSE TEST ERROR	1 slow flashes 9 quick flashes	Closing safety contact autotest error	Check that the device connected to the closing safety contact is in good condition and correctly installed
Er26 STOP	2 slow flashes 6 quick flashes	The panel has stopped due to a STOP or due to an encoder STOP	Check that the STOP input has been activated
Er30 RBAND DOES NOT EXIST	3 slow flashes 10 quick flashes	The panel had been programmed with RBAND and it is no longer there	Re-program the panel without RBAND or connect the RBAND with which the panel had been programmed
Er31 RBAND NC IN PROG	3 slow flashes 1 quick flashes	The panel has not been programmed with RSEC3 connected	Re-program the panel with the RSEC3 card connected

Er32	FC NOT LEARNT	3 slow flashes 2 quick flashes	Error in limit switches learning	Check the motor's internal limit switches
Er39	PANEL LOCKED	3 slow flashes 9 quick flashes	An attempt has been made to enter programming with the panel locked	Enter the password with the V-DPLAY or VERSUS-PROG to unlock the control panel
Er41	ENCODER ERROR	4 slow flashes 1 quick flashes	No absolute encoder found or the encoder itself is returning an error	Check absolute encoder connection.
Er43	FREQ. CONVERTER ERROR	4 slow flashes 3 quick flashes	Frequency converter error	Check frequency converter parameters configuration or check connections.

In case of any safety error, the door can be moved keeping pressed the  buttons or any other input controls.  or 

Technical data

Electrical parameters

PARAMETER	VALUE
Power supply	230Vac ~
Maximum motor power	230Vac 3~ 1,5kW
Optional cards (EXPANSION1/EXPANSION2)	RSEC3, TL-CARD-V
Receiver card connector	Motion STICK / DCS RACK
230V output	Motor brake and flashing
Voltage-free outputs	OPEN/CLOSE door status signals
24Vac / 24Vdc / 24Vdc TEST outputs	Accessories power supply / Photocells test (shared 700mA)
ENCODER connector	Connector for absolute encoder JCM / Kostal / Elektromaten
Auto-close time	Adjustment from 3s to 180s
Operating temperature	-20°C a +55°C
IP rating	IP65
Size	305 x 225 x 126 mm
Inverter	Danfoss FC51

F30 1.5KW

Braking resistance for motors up to 1.5kW. Cycles of operation according to type and size of door as well as motor consumption in table (please use the data as guidance).

Door	Motor	Maneuvers per minute
Stackable maximum 5400x5500mm	1,1kW	1 maneuver/minute
Stackable 4700x3800mm	0,55kW	5 maneuvers/minute
Rolling door 4200x3800mm	0,55kW	5 maneuvers/minute

Regulatory data

EU Declaration of conformity

JCM TECHNOLOGIES, SAU declares that the product **F30 1.5KW** complies with the relevant fundamental requirements of the Machine Directive 2006/42/EC as well as with the Directives 2014/30/EU on electromagnetic compatibility and 2014/35/EU regarding low voltage whenever its usage is foreseen; and with the 2011/65/EU RoHS Directive.

EKCA Declaration of conformity

JCM TECHNOLOGIES, SAU hereby declares that the product **F30 1.5KW** complies with the relevant fundamental requirements of the Supply of Machinery (Safety) Regulations 2008 as well as with the Electromagnetic Compatibility Regulations 2016 and the Electrical Equipment (Safety) Regulations 2016 whenever its usage is foreseen; and with the RoHS Regulations 2012.

See website www.jcm-tech.com/en/declarations

JCM TECHNOLOGIES, SAU
C/COSTA D'EN PARATGE, 6B
08500 VIC (BARCELONA)
SPAIN

UM_3201217_F30 1.5KW_EN_Rev03

