

# User's Manual

## IP-12+

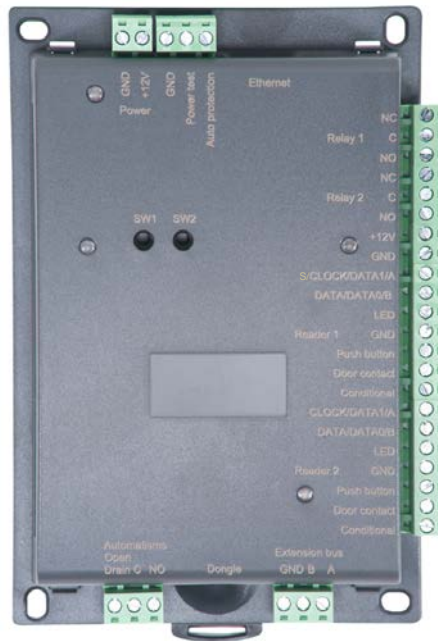

## CONTENTS

<b>CONTENTS</b> .....	<b>1</b>
<b>INFORMATION AND RECOMMENDATIONS</b> .....	<b>2</b>
<b>TECHNICAL CHARACTERISTICS</b> .....	<b>2</b>
<b>COMPATIBILITY</b> .....	<b>2</b>
<b>CONNECTING A DEVICE USING S BUS, WIEGAND, CLOCK&amp;DATA OR RS485 PROTOCOLS</b> .....	<b>3</b>
<b>CONNECTING IP-EXT4+ AND IP-EXTIO MODULES</b> .....	<b>4</b>
<b>CONNECTING A POWER LOSS BOLT AND AN ELECTROMAGNETIC DOOR LOCK OPERATING ON POWER LOSS</b> .....	<b>5</b>
<b>CONNECTING A STANDARD POWER-ON DOOR LOCK</b> .....	<b>6</b>
<b>CONNECTING THE IP-12+ UNIT TO AN ETHERNET NETWORK</b> .....	<b>7</b>
<b>INSTALLATION OF DOMOS DONGLE</b> .....	<b>8</b>
<b>FUNCTIONS OF THE TERMINALS</b> .....	<b>9</b>
<b>USE OF THE RESET BUTTONS</b> .....	<b>10</b>

## INFORMATION AND RECOMMENDATIONS



- JCM Technologies S.A. hereby declares that the product IP-12+ complies with the relevant fundamental requirements of the Directives 2014/30/EU on electromagnetic compatibility whenever its usage is foreseen; and with the 2011/65/EU RoHS Directive.

JCM TECHNOLOGIES, SA  
BISBE MORGADES, 46 BAIXOS  
08500 VIC (BARCELONA)  
SPAIN

See website [www.jcm-tech.com/en/declarations](http://www.jcm-tech.com/en/declarations)

- **Cabling recommendations:** the cables used to connect readers, and the network and other peripherals must be installed in accordance with the instructions for Level 2 (protected environment) of standard NF EN 61000-4-4.
- **This product must be installed by an approved company.** Incorrect installation and use may result in electric shock or fire. Before installation, read the technical information and comply with the recommendations for assembling the product.

## TECHNICAL CHARACTERISTICS

### **IP-12+**

Maximum power consumption..... 300 mA  
Supply voltage..... 9 – 14VDC  
Weight with housing ..... 257 g  
Housing dimensions ..... 170 x 116 x 40 mm  
Operating temperature ..... 0°C a + 50°C  
Control relay ..... 1A / 12V – 1A / 24V

## COMPATIBILITY

The IP-12+ devices are compatible with the version 2.0.0.20 (or greater) of the Domos software.

For downloading the last version, use the link: <https://www.jcm-tech.com/JCM/domos/>

The IP-12+ devices are compatibles with the modules IP-EXT4, IP-EXT4+ and IP-EXTIO.

# CONNECTING A DEVICE USING S BUS, WIEGAND, CLOCK&DATA OR RS485 PROTOCOLS



**S BUS (+12V,GND,S):**

- o JCM devices

**WIEGAND (+12V,GND,DATA1, DATA0,LED):**

- o Proximity readers
- o Key pads
- o Biometric readers
- o Radio receivers

**CLOCK & DATA (+12V,GND,CLOCK, DATA,LED):**

- o Magnetic strip readers
- o Barcode readers
- o Proximity readers
- o Radio receivers

**RS485 (+12V,GND,A, B,GND):**

- o DIGIBIO MINI

**Information:**

5 conductors (3 pairs recommended)

Max. distance: 150 m

Cable type: 0.6 mm (SYT recommended)

Shield: Optional

**Warning:** Do not install the unit-reader cables near other high voltage or high current cables, particularly 220V or higher.

**Note:** Each reader can have different technology (e.g. Reader 1 using Wiegand, Reader 2 using Clock & Data), except S BUS.

**Warning:** If you use an external power supply for your proximity readers, take care to **connect the various earths to that of the unit.**

# CONNECTING IP-EXT4+ AND IP-EXTIO MODULES

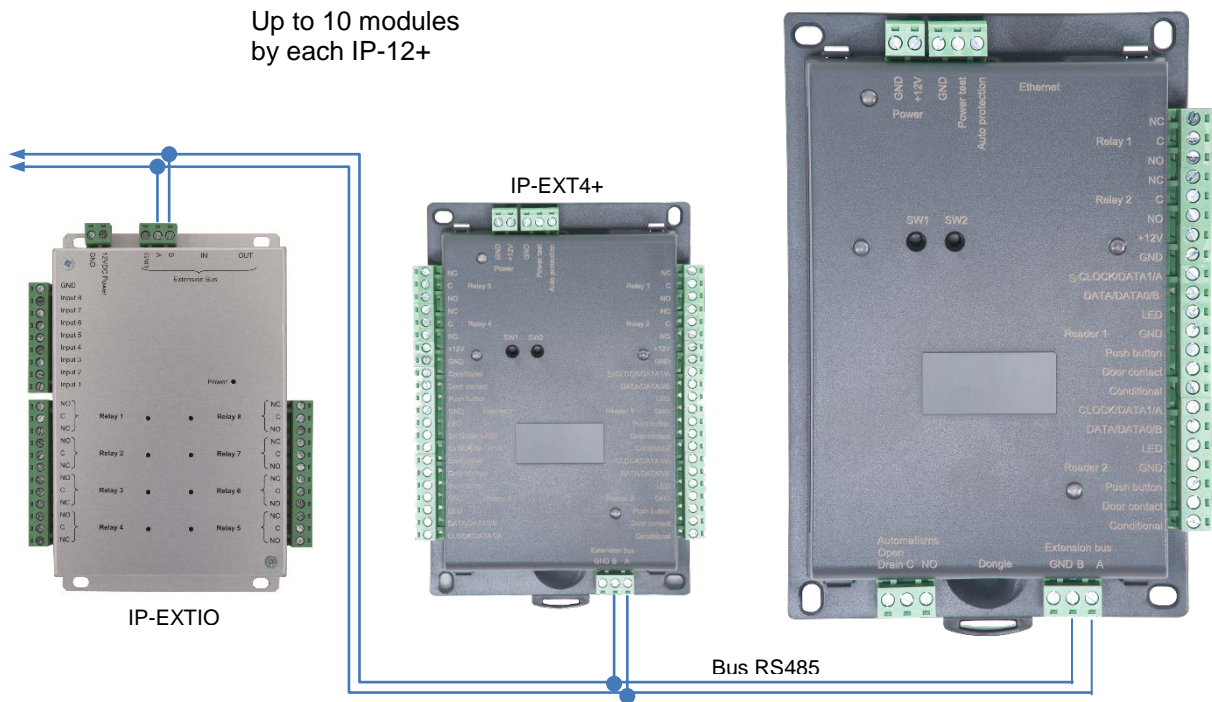

You can also use the A and B terminals on the IP-EXT4+ modules to connect an RS485 bus.

## Information:

2 conductors (2 pairs recommended)

Max. distance: 750 m

Cable type: 0.6 mm (SYT recommended)

**Warning:** Do not install the cables near other high voltage or high current cables, particularly 220V or higher. Use the same pair for the A and B lines.

## CONNECTING A POWER LOSS BOLT AND AN ELECTROMAGNETIC DOOR LOCK OPERATING ON POWER LOSS

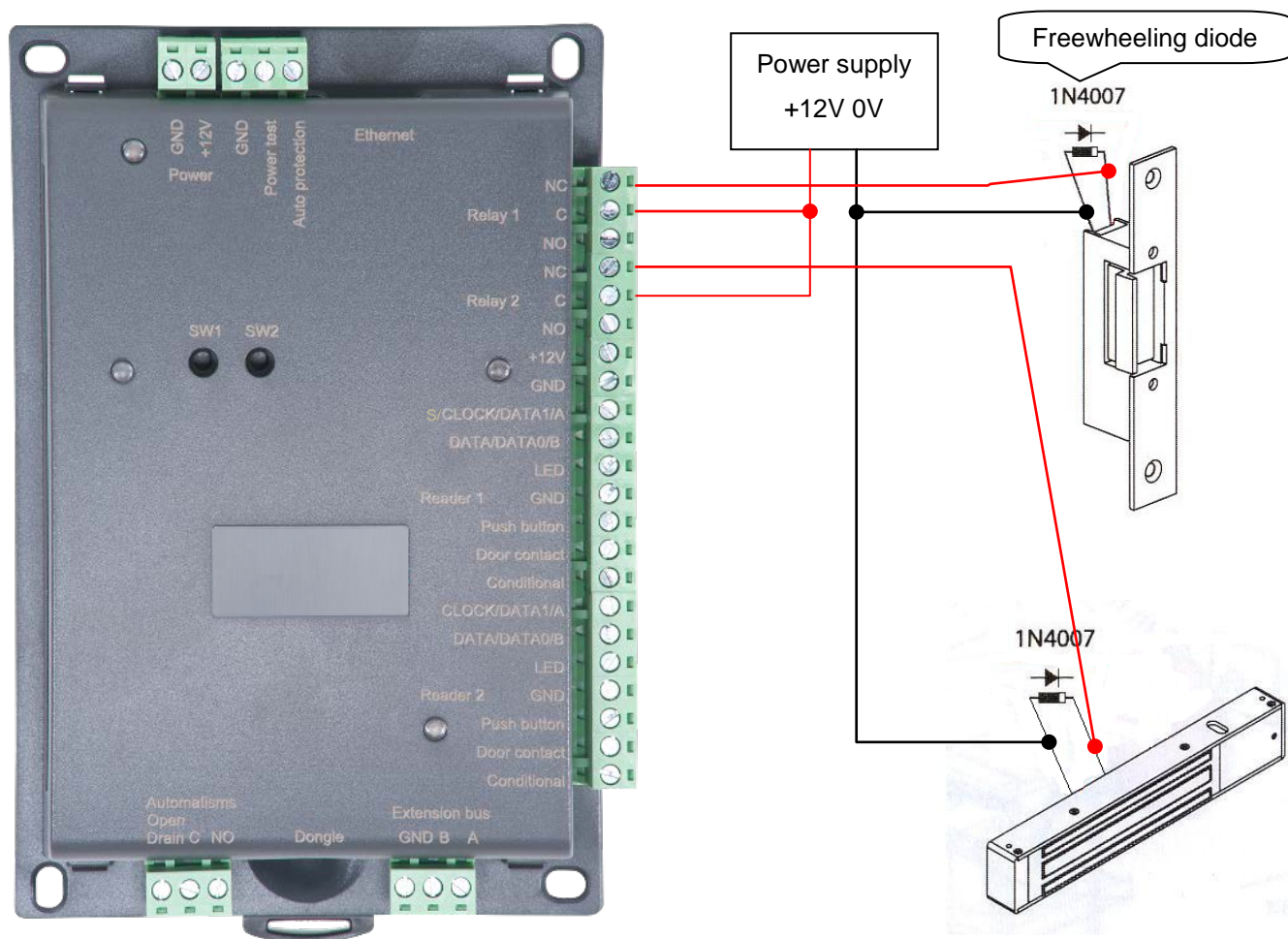

**Warning:** In order to prevent random malfunctions that may interfere with proper system operation due to back-currents, it is imperative to use and connect the anti-back-current diodes supplied with the unit in compliance with the cabling diagram above.

Even when using an additional uninterruptible power supply for locking separate to that of the unit, it is obligatory to follow the above cabling diagram.



## CONNECTING A STANDARD POWER-ON DOOR LOCK

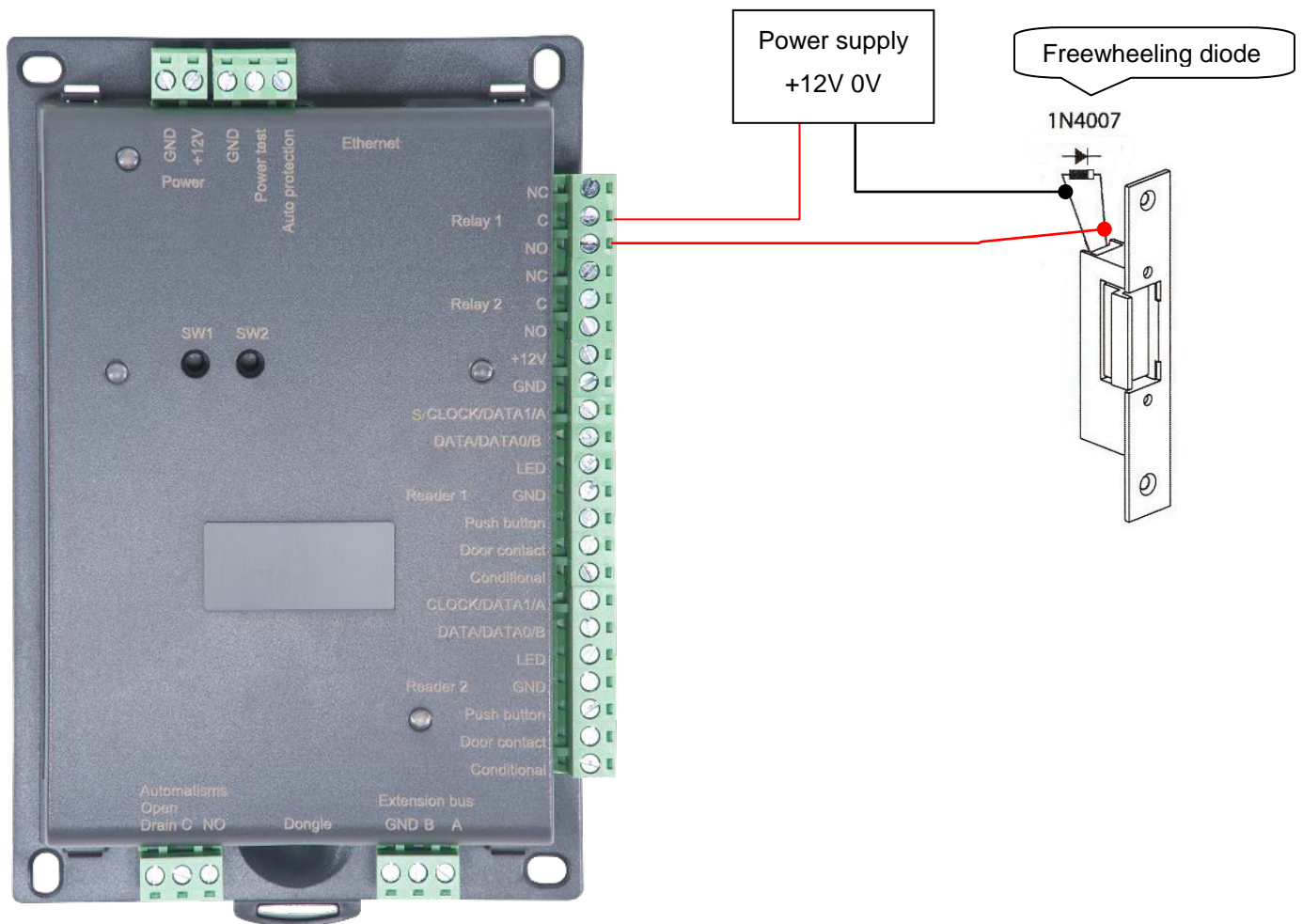

**Warning:** In order to prevent random malfunctions that may interfere with proper system operation due to back-currents, it is imperative to use and connect the anti-back-current diodes supplied with the unit in compliance with the cabling diagram above.

Even when using an additional uninterruptible power supply for locking separate to that of the unit, it is obligatory to follow the above cabling diagram.

## CONNECTING THE IP-12+ UNIT TO AN ETHERNET NETWORK

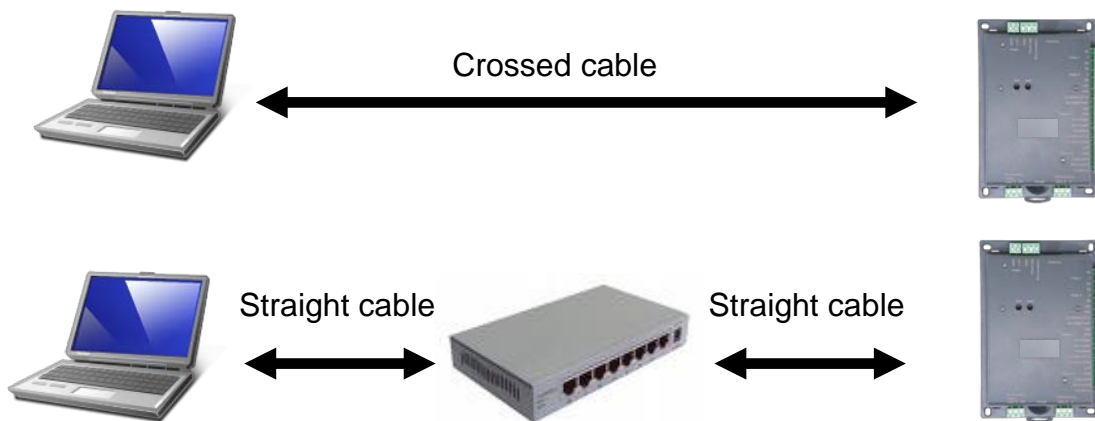

Each IP-12+ unit has an IP address. This address is printed on a sticker on the unit housing.

To configure a different IP address, you can use the “Automatic detection” menu in DOMOS. To do this, proceed as follows:

- After having created your installation, on first start up, DOMOS offers to create a new unit
- Click on the “Search” button
- A list of detected units will appear
- Double click on the unit you want to add
- Check the equipment list to confirm that your unit is properly connected.

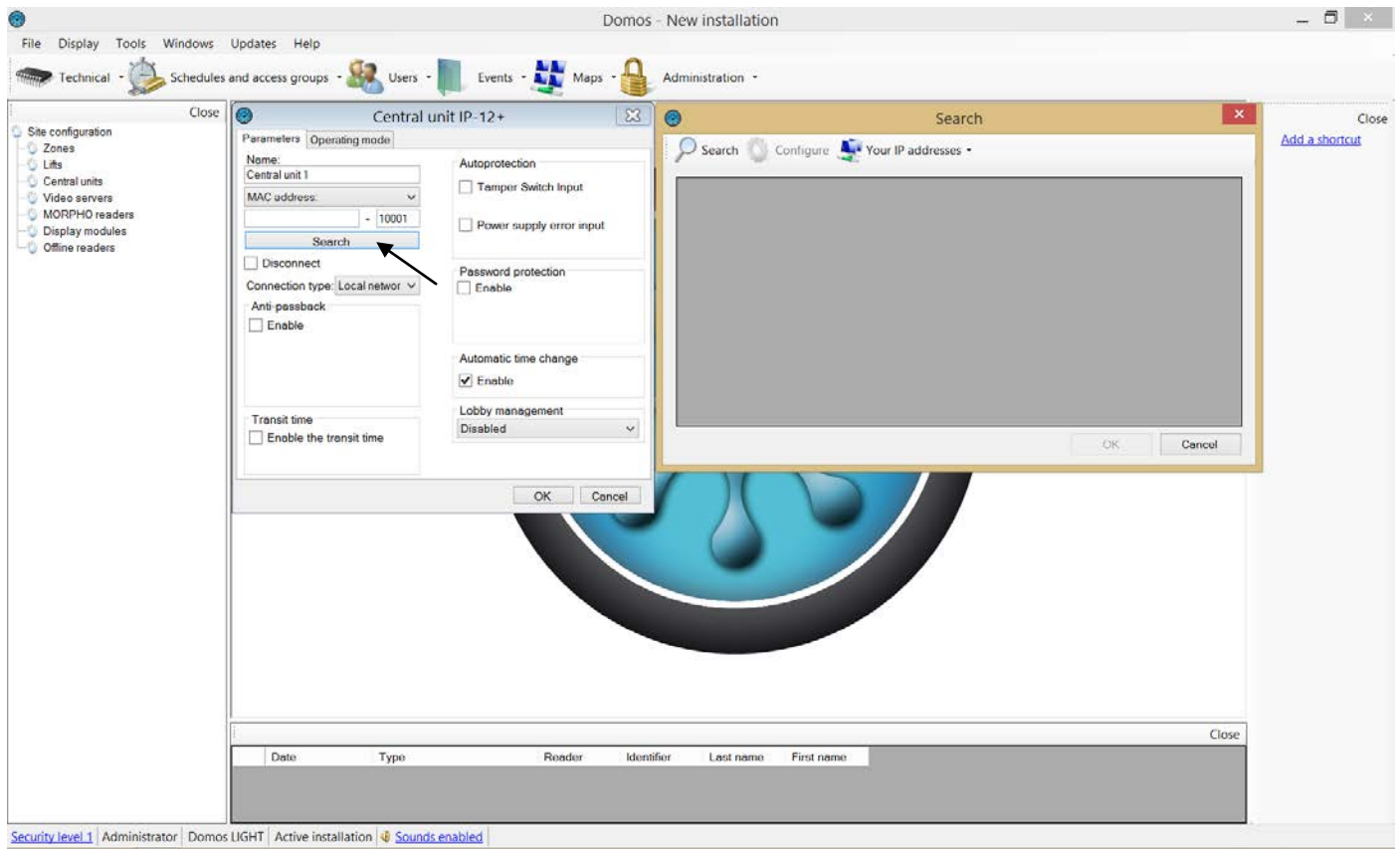

## INSTALLATION OF DOMOS DONGLE

To use the DOMOS software, you must, in certain cases (see following table), install a dongle on your unit.

Use of the dongle

Number of readers in the installation	Dongle	License
Up to 4 readers	NO dongle required	-
Up to 10 readers	Dongle required	DOMOS-10
Up to 40 readers	Dongle required	DOMOS-40
Up to 80 readers	Dongle required	DOMOS-80
Up to 140 readers	Dongle required	DOMOS-140
Up to 840 readers	Dongle required	DOMOS-840

Installation of dongle: **with the power off**, install the dongle as shown below:

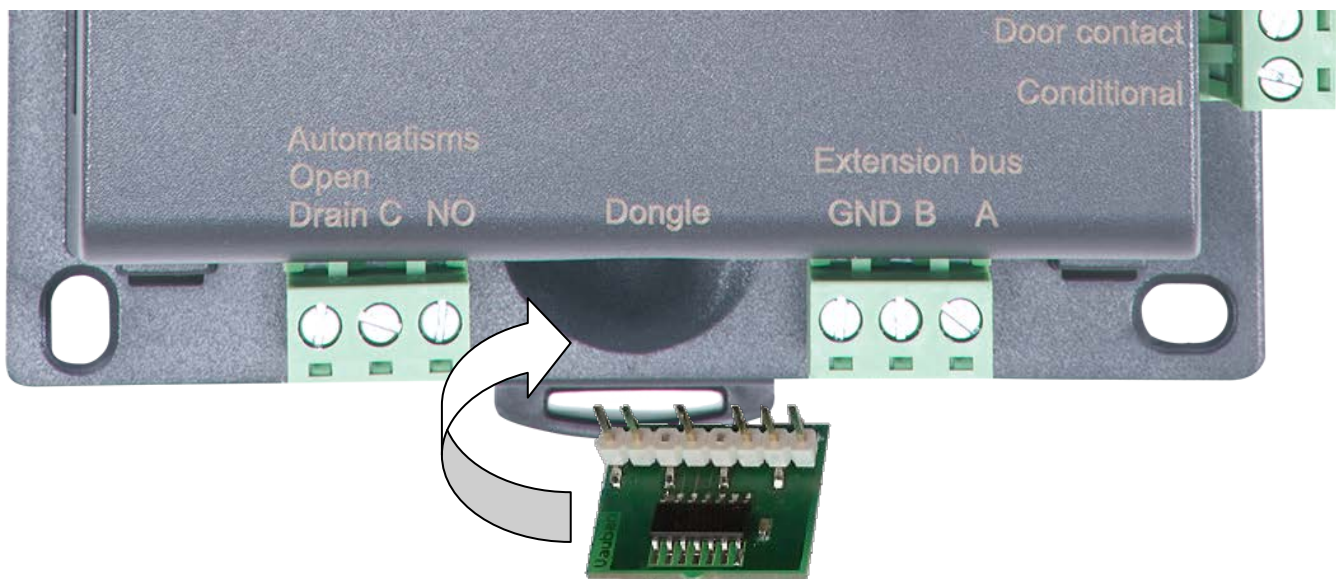

To confirm proper operation, DOMOS shows the version being used at the bottom of the main screen. Your unit must be rated for the dongle to be detected.

If you do not have the correct dongle for your installation type, your units will be displayed "rated" in the equipment list but no updates or event collection will be performed.



# FUNCTIONS OF THE TERMINALS

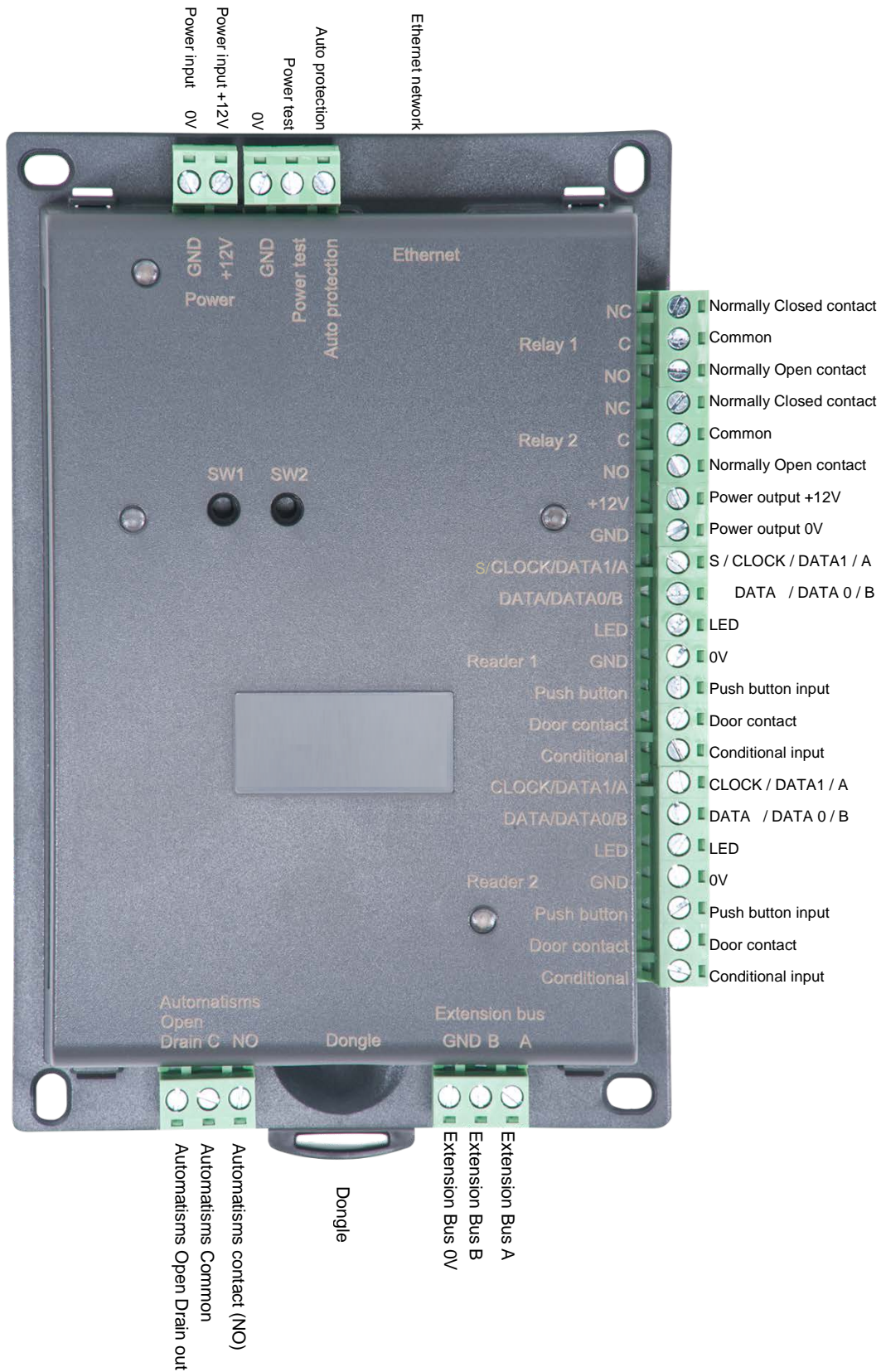

## USE OF THE RESET BUTTONS

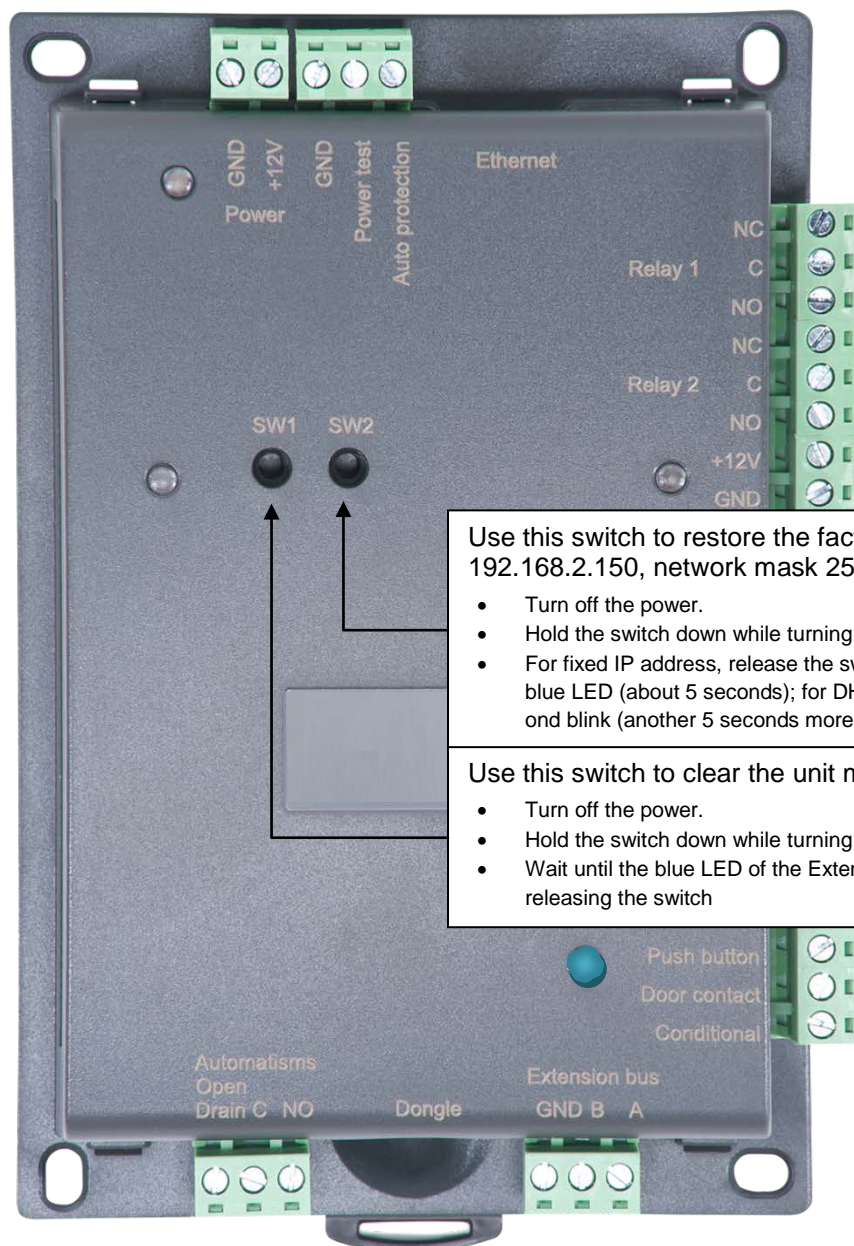

Use this switch to restore the factory network settings (IP address: 192.168.2.150, network mask 255.255.255.0)

- Turn off the power.
- Hold the switch down while turning the power back on
- For fixed IP address, release the switch after the first blink of the Extension bus blue LED (about 5 seconds); for DHCP mode, release the switch after the second blink (another 5 seconds more)

Use this switch to clear the unit memory

- Turn off the power.
- Hold the switch down while turning the power back on
- Wait until the blue LED of the Extension bus blinks (about 10 seconds) for releasing the switch