

electronic solutions for doors, gates and automatic
entry control elements

Free

hands-free system for
vehicles and people



any door will open
within 1.5, 3 or 5 metres

jcmtechnologies

be a step ahead with technology and imagination



Free30r

Nominal range: 3 metros
Power supply: 12/24Vac/dc



Free50r

Nominal range: 5 metros
Power supply: 230V
Presence detector contact



Free15r

Nominal range: 1.5 metros
Power supply: 12/24Vac/dc



FreeTH

Active tag
Luminous operation indicator
Low battery warning
Receiver programming by proximity
Ideal for controlling wandering people: Geriatric Homes - Hospitals - Offices



FreeT

Active tag
Acoustic operation indicator
Low battery warning
Receiver programming by proximity or button
Ideal for controlling access: Offices - Car parks - Industries



Free

hands-free system for vehicles and people

With the **FREE** hands-free system, all doors can be opened without having to press any button.

With the JCM hands-free system you will be able to open any door without having to press any buttons.

When you walk into the range of action of the Free**15r/30r/50r** antenna with the Free**T/TH**, the antenna goes off and sends a radio signal that can reach up to 100 metres in an open space.

It is very simple to install because it does not require wiring as it works with radio signals. The ranges of action of the antennas go from one metre and a half to five metres, depending on the model.

The Free**T** range has been designed to be used in vehicles, as well as for individual use of pedestrians, in private and professional areas, enabling the control of the access of people and goods.

The Free**TH** is a multipurpose product, specially designed to control wandering people, to locate people in buildings, to control presence, emergency and evacuation plans... in companies, offices, banks, sports centres, hospitals and geriatric homes, amongst others.

Free

hands-free systems for vehicles and people

be different

Be different thanks to the advantages of the hands-free systems. Professionals who purchase and install this product will be able to offer their clients an innovative and leading system in this sector.



Hands-free and button for voluntary activation

The Hands-Free system combines hands-free activation with button activation on the FreeT device.

A two-directional communication with feedback for the user can be established.

Low-cost hands-free system

The Free hands-free system also stands out because of its price – it is affordable for small residential estates (50 users) and even for individuals.

Free

hands-free systems for vehicles and people

be different

Benefits for distributors and installers

Become an important distributor/installer of innovative and technological products with an increasing demand on the market.

MOTION devices (for JCM distributors).

Access to new applications and installations.

Hands-free for controlling access.

Benefits for the user

Highly convenient (no buttons required to open the door).

Higher security because the activation area is completely defined by the system.

FreeTH is a multipurpose product, specially designed to control wandering people, to locate people in buildings, to control presence, emergency and evacuation plans.

Versatile to use because FreeT can be used as a standard transmitter with no presence of hands-free triggers.

Can be used in MOTION access control centres.

FreeT supplied with clothes clip and car stand.

FreeTH supplied with single-use or multipurpose wristband.

With acoustic activation feedback and low battery warning.



FreeT

The receiver can be activated manually with a button within 100 m



100 m



Free

hands-free systems for vehicles and people
versatility

Group concept

Thanks to the innovative group concept and anti-collision system, the FreeT tag can open up to 21 different doors in the same installation and the FreeTH 28. Ideal for applications with fast doors and control of wandering people.

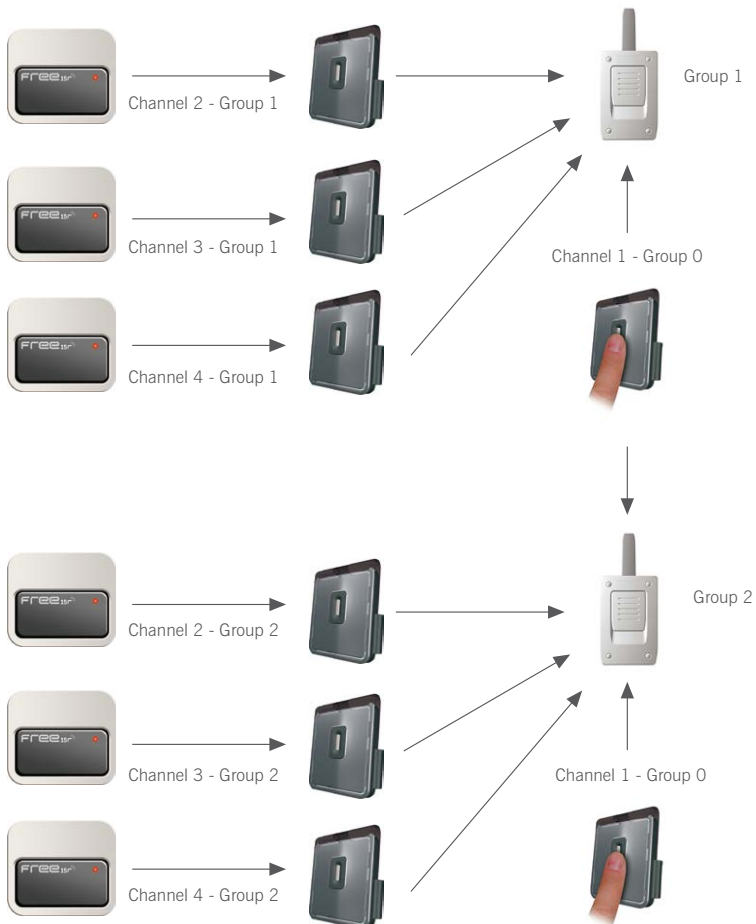

Independent trigger

The Free**15r**, Free**30r** and Free**50r** triggers are completely independent from the receiver; they only need power supply to work. When a Tag Free gets close enough to the trigger, it turns on and sends a signal to the receiver at a distance of up to 100 metres.

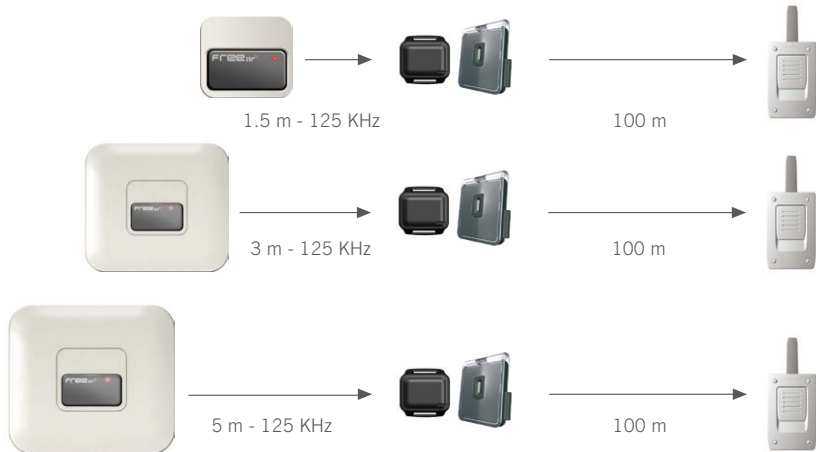

Access control



Free

hands-free systems for vehicles and people

versatility

Receiver power supply

Both trigger models, Free**15r** and Free**30r**, require 12 - 24V, direct and alternating.

The Free**50r** models require 230V.

Individual installation

It must be connected to a power supply of 12 - 24Vac/dc or 230V as the diagram shows. We recommend short-circuiting the IN and OUT synchronisation signals.

If the presence detection is not use in the version Free50r, the presence cable has to be joined up with the ground wire.

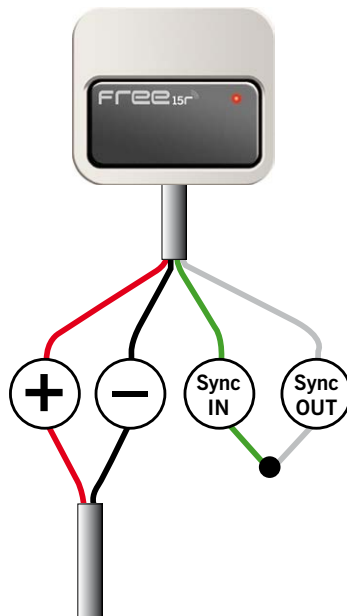

Collective installation

In a collective installation system of triggers (different versions of triggers can be connected), they must be connected in series, up to four units.

In order to work properly, the synchronisation signal OUT must be connected to the synchronisation signal IN of the next trigger, and when we get to the last unit, we link it up to the first one, following the same diagram (this connection is only necessary when the same door is going to be opened with more than one antenna and we want to extend the hands-free distance).

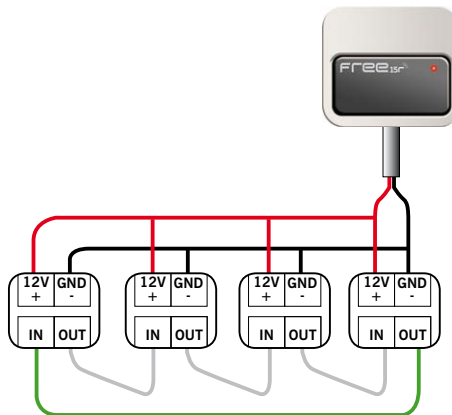

2 years of autonomy

The size and the type of batteries have been designed to guarantee a duration of about 2 years.

Controlling the status of the batteries

Low battery warning on the transmitter with an acoustic signal.

Free

hands-free systems for vehicles and people

reliability

Control of the hands-free activation

While the **Free** hands-free tag is in the area of activation, the activation button must be pressed to activate the tag again or to leave and enter in this area again.

High precision of the activation

With the **Free15r** trigger, the hands-free tag is activated within 1.5 meters, ideal for pedestrians.

With the **Free30r/50r** triggers, the distance of activation will be 3 to 5 metres, ideal for vehicles.

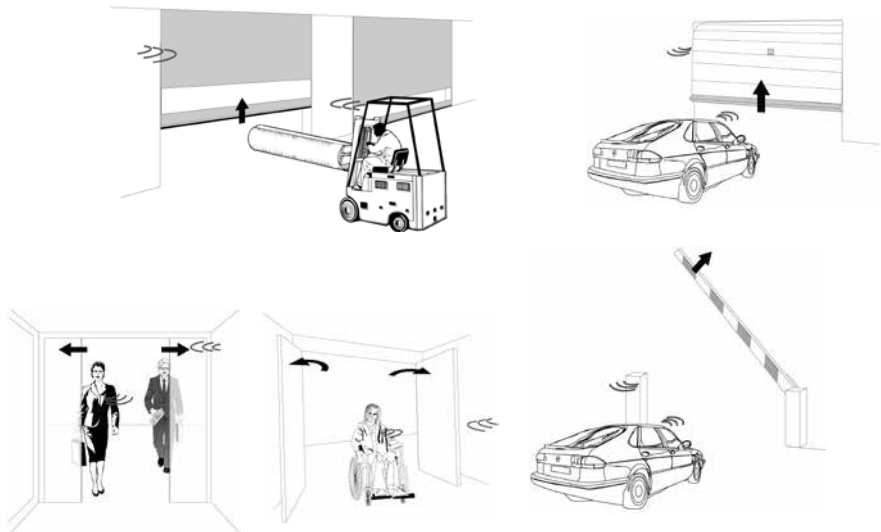

Free

hands-free systems for vehicles and people

Free50 operation

The Free**50r** model can work with or without presence detector. If you do not wish to use the detector, the presence cable must be connected with the ground wire, and it works just like the Free**15r**, Free**30r**, but it comes on at a distance of 5 m.

When you want to connect the presence detector to the antenna, either with a photocell or a magnetic detector, it is connected with the presence cable and the ground wire. When it detects presence, the tag activation comes on.

PERSONS	CAR	WALL
3.5 A 5 METERS	FRONT 5.0 A 5.5 METERS - SIDE 6.0 A 6.5 METERS	7.0 METERS

All the models in this range can be used with an **ACTIVAGO**, a **CONNECT** and all the **MOTION** receivers and central units.



ACCESS1000



WAVE500
ACCESS500



BASE



STICK



CONNECT



ACTIVAGO

Free

hands-free systems for vehicles and people
certifications



ISO 9001



EUROPEAN UNION
CERTIFICATION



FEDERAL COMMUNICATION
COMMISSION



www.jcm-tech.com